

PART NUMBER	NOM DIA.		A HEX.		C MAX.		D DIA.		F FLATS		H HEAD HEIGHT		J DIA. MAX.		K MAX.		L1 REF.		L3 REF.	
	INCH	mm	INCH	mm	INCH	mm	INCH	mm	INCH	mm	INCH	mm	INCH	mm	INCH	mm	INCH	mm	INCH	mm
PLT5270-05-(-)	.1635	4,153	.250 .244	6,35 6,20	.285	7,24	.1645 .1625	4,178 4,128	.086 .081	2,18 2,06	.096 .070	2,44 1,78	.244	6,20	.257	6,53	.328	8,33	.673	17,09
PLT5270-06-(-)	.1980	5,029	.312 .305	7,92 7,75	.320	8,13	.1990 .1970	5,055 5,004	.104 .099	2,64 2,52	.113 .074	2,87 1,88	.300	7,62	.288	7,31	.373	9,47	.658	16,71
PLT5270-08-(-)	.2590	6,579	.375 .367	9,52 9,32	.355	9,02	.2600 .2580	6,604 6,553	.135 .130	3,43 3,30	.135 .084	3,43 2,13	.384	9,75	.320	8,13	.417	10,59	.754	19,15
PLT5270-10-(-)	.3105	7,887	.437 .429	11,10 10,90	.440	11,18	.3115 .3095	7,912 7,861	.152 .147	3,86 3,73	.160 .106	4,06 2,69	.427	10,85	.396	10,06	.536	13,61	.985	25,02
PLT5270-12-(-)	.3735	9,487	.500 .491	12,70 12,47	.525	13,34	.3745 .3725	9,512 9,462	.185 .180	4,70 4,57	.190 .127	4,83 3,22	.516	13,11	.473	12,01	.645	16,38	1.001	25,43

PART NUMBER	R RAD.		W REF. DRIVE NUT		BREAK-OFF LIMITS		MINIMUM AVAILABLE GRIP LENGTH	HOLE SIZE		PREVAILING TORQUE MIN.		DOUBLE SHEAR STRENGTH MIN.		TENSILE STRENGTH MIN.	
	INCH	mm	INCH	mm	INCH	mm		INCH	mm	IN-LBS	Nm	LBS.	N	LBS.	N
PLT5270-05-(-)	.020 .010	0,51 0,25	.375	9,52	+0,88 +0,00	+2,23 +0,00	-01	.168 .165	4,27 4,19	1.0	0,113	3150	14010	900	4000
PLT5270-06-(-)	.025 .015	0,63 0,38	.375	9,52	+0,98 +0,10	+2,49 +0,25	-01	.202 .199	5,13 5,05	1.5	0,170	4600	20460	1400	6230
PLT5270-08-(-)	.025 .015	0,63 0,38	.375	9,52	+1,35 +0,47	+3,43 +1,19	-02	.263 .260	6,68 6,60	2.5	0,282	7900	35140	2100	9340
PLT5270-10-(-)	.030 .015	0,76 0,38	.500	12,70	+1,46 +0,43	+3,71 +1,09	-02	.315 .312	8,00 7,92	3.5	0,400	11350	50480	3600	16010
PLT5270-12-(-)	.030 .015	0,76 0,38	.500	12,70	+1,52 +0,49	+3,86 +1,24	-03	.378 .375	9,60 9,52	4.0	0,452	16450	73170	5600	24910

MONOGRAM AEROSPACE FASTENERS
a TriMas company
3423 SOUTH GARFIELD AVENUE
COMMERCE, CALIFORNIA 90040
(323) 722-4760 FAX (323) 727-1029

TITLE:
**VISU-LOK® II, FASTENER, BLIND
HEXAGONAL PROTRUDING HEAD
NOMINAL DIAMETER
TITANIUM ALLOY**

DRAWING NO:
PLT5270()-()-()

DRAWN BY: **G.MARTINEZ** DRAWN DATE: **08-19-13**

APPROVED BY: CHECKED DATE:

PROPRIETARY AND CONFIDENTIAL:
NOTICE: THIS DRAWING IS PART OF THE PROPRIETARY ARTICLE HEREIN DISCLOSED, OWNED BY MONOGRAM AEROSPACE FASTENERS. ANY PARTY BY ACCEPTING THIS DOCUMENT ASSUME CUSTODY THEREOF AND AGREES:
A: THE INFORMATION SET FORTH HEREIN IS GIVEN IN CONFIDENCE AND THIS DOCUMENT WILL NOT BE COPIED OR REPRODUCED IN WHOLE OR IN PART, NOR ITS CONTENTS REVEALED IN ANY MANNER TO ANY PERSON EXCEPT TO MEET THE PURPOSE FOR WHICH IT WAS DELIVERED.
B: WITHOUT THE WRITTEN CONSENT OF MONOGRAM AEROSPACE FASTENERS, THIS DOCUMENT AND THE INFORMATION CONTAINED HEREIN UNDER NO CIRCUMSTANCES WILL BE USED IN THE MANUFACTURE OR REPRODUCTION OF THE ARTICLE DISCLOSED, AND THE DELIVERY OF THIS DOCUMENT SHALL NOT CONSTITUTE ANY RIGHT OR LICENSE TO DO SO.

Alcoa CAGE CODE: **5M902**

MONOGRAM CAGE CODE: **98524**

ECN NO: **14-0801** REV: **R**

ECN DATE: **11/18/14** SHEET 1 OF 2

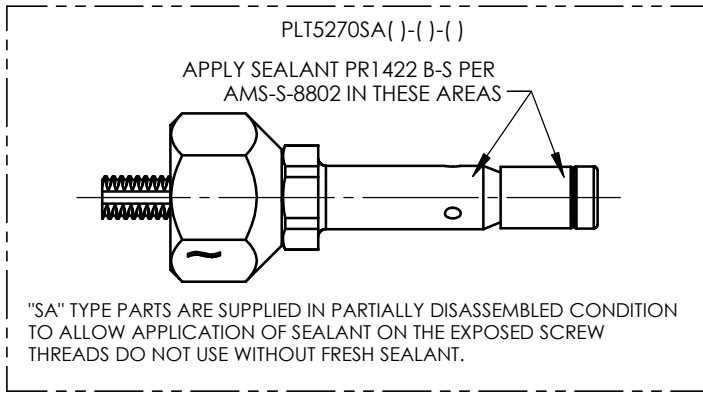

PROCUREMENT SPEC:

PROCUREMENT SPECIFICATION = PLT5000, CLASS 5, TYPE V
 PART NUMBER ASSIGNMENT = PLT5001
 INSTALLATION AND REMOVAL = PLT5002
 SPECIAL LUBE AND FINISH = PLT5003

MATERIAL:

NUT & SCREW: 6AL-4V TITANIUM PER AMS4928 OR AMS4967.
 SLEEVE: 303 OR 304 CORROSION RESISTANT STEEL PER AMS5639 OR AMS5641 OR A286
 PER AMS5731, AMS5732, OR AMS5737.
 DRIVE NUT: MILD STEEL.

HEAT TREAT:

NUT & SCREW: HEAT TREAT TO 95 KSI, FSU.
 SLEEVE & DRIVE NUT: AS REQUIRED FOR PERFORMANCE.

FINISH:

" - " CODE:
 NUT & SCREW: NONE.
 SLEEVE: PASSIVATE PER AMS2700.
 DRIVE NUT: CORROSION RESISTANT COATING. COLOR GRAY.

"AD" CODE:
 NUT: ANODIZE PER AMS2488, TYPE II.
 SCREW: NONE.
 SLEEVE: PASSIVATE PER AMS2700.
 DRIVE NUT: CORROSION RESISTANT COATING. COLOR GRAY.

LUBRICANT:

SOLID DRY FILM LUBE PER THE CHEMICAL REQUIREMENTS OF AS5272 TYPE I, OR EVERLUBE 812 PER MIL-PRF-81329, PARAFFIN WAX OR CETYL ALCOHOL PER AS87132 MAY BE APPLIED TO ANY OR ALL COMPONENTS AS REQUIRED FOR PERFORMANCE. (SEE PLT 5003 FOR SPECIAL LUBRICANTS AND FINISHES).

PART CODE & EXAMPLE:

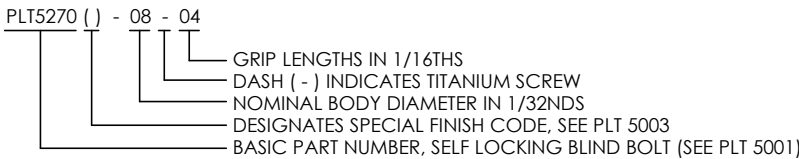

GENERAL NOTES:

1. LOCKING FEATURE CONSISTS OF THREE (3) INDENTATIONS LOCATED 120° APART ON THE PERIPHERY OF THE NUT COMPONENT.
2. HALF-GRIP SIZES MAY BE ORDERED BY ADDING (.5) TO THE GRIP DASH NUMBERS.

 EXAMPLE: PLT5270-06-4.5 INDICATES A NOMINAL GRIP LENGTH OF 4.5 SIXTEENTHS = 0.281" (7.14mm) AND A GRIP RANGE OF .250" THRU .312" (6.35mm THRU 7.92mm).
3. DISTORTION OF "D" DIAMETER SHALL NOT PREVENT INSERTION OF THE FASTENER INTO A RING GAUGE OF LENGTH EQUAL TO ONE DIAMETER AND DIAMETER EQUAL TO MINIMUM RECOMMENDED HOLE SIZE. FORCE FOR INSERTION SHALL NOT EXCEED FIVE (5) POUNDS (22.23 NEWTONS).
4. SECOND DASH NUMBER (GRIP RANGE) -17 THROUGH -32 NOT AVAILABLE IN -05 DIAMETER.
5. HEAD MARKINGS DEPRESSED .010" (0.254mm MAX.).

△ 2ND DASH NO.	GRIP RANGE △			
	GRIP MIN.		GRIP MAX.	
	INCH	mm	INCH	mm
-01	.031	0,79	.093	2,36
-02	.094	2,39	.156	3,96
-03	.157	3,99	.219	5,56
-04	.220	5,59	.281	7,14
-05	.282	7,16	.344	8,74
-06	.345	8,76	.406	10,31
-07	.407	10,34	.469	11,91
-08	.470	11,94	.531	13,49
-09	.532	13,51	.594	15,11
-10	.595	15,11	.656	16,66
-11	.657	16,69	.719	18,26
-12	.720	18,29	.781	19,84
-13	.782	19,86	.844	21,44
-14	.845	21,46	.906	23,01
-15	.907	23,04	.969	24,61
-16	.970	24,64	1.031	26,19
-17	1.032	26,21	1.094	27,79
-18	1.095	27,81	1.156	29,36
-19	1.157	29,39	1.219	30,96
-20	1.220	30,99	1.281	32,54
-21	1.282	32,56	1.344	34,14
-22	1.345	34,16	1.406	35,71
-23	1.407	35,74	1.469	37,31
-24	1.470	37,34	1.531	38,89
-25	1.532	38,91	1.594	40,49
-26	1.595	40,51	1.656	42,06
-27	1.657	42,09	1.719	43,66
-28	1.720	43,69	1.781	45,24
-29	1.782	45,26	1.844	46,84
-30	1.845	46,86	1.906	48,41
-31	1.907	48,44	1.969	50,01
-32	1.970	50,04	2.031	51,59

3423 SOUTH GARFIELD AVENUE
 COMMERCE, CALIFORNIA 90040
 (323) 722-4760 FAX (323) 727-1029

TITLE:
 VISU-LOK® II, FASTENER, BLIND
 HEXAGONAL PROTRUDING HEAD
 NOMINAL DIAMETER
 TITANIUM ALLOY

DRAWING NO:
 PLT5270()-()-()

DRAWN BY: G.MARTINEZ DRAWN DATE: 08-19-13

APPROVED BY: CHECKED DATE:

PROPRIETARY AND CONFIDENTIAL:
 NOTICE: THIS DRAWING IS PART OF THE PROPRIETARY ARTICLE HEREIN DISCLOSED, OWNED BY MONOGRAM AEROSPACE FASTENERS. ANY PARTY BY ACCEPTING THIS DOCUMENT ASSUME CUSTODY THEREOF AND AGREES:
 A: THE INFORMATION SET FORTH HEREIN IS GIVEN IN CONFIDENCE AND THIS DOCUMENT WILL NOT BE COPIED OR REPRODUCED IN WHOLE OR IN PART, NOR ITS CONTENTS REVEALED IN ANY MANNER TO ANY PERSON EXCEPT TO MEET THE PURPOSE FOR WHICH IT WAS DELIVERED.
 B: WITHOUT THE WRITTEN CONSENT OF MONOGRAM AEROSPACE FASTENERS, THIS DOCUMENT AND THE INFORMATION CONTAINED HEREIN UNDER NO CIRCUMSTANCES WILL BE USED IN THE MANUFACTURE OR REPRODUCTION OF THE ARTICLE DISCLOSED, AND THE DELIVERY OF THIS DOCUMENT SHALL NOT CONSTITUTE ANY RIGHT OR LICENSE TO DO SO.

Alcoa CAGE CODE: 5M902

MONOGRAM CAGE CODE: 98524

ECN NO: 14-0801 ECN DATE: 11/19/14

REV: R

SHEET 2 OF 2