

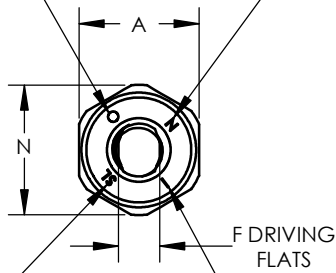

ALLOY IDENTIFICATION  
 ○ INDICATES A-286 STEEL

△△ MANUFACTURER'S IDENTIFICATION  
 MONOGRAM = "N"  
 VOI-SHAN = "VS"



"SL" INDICATES SELF LOCKING

DASH "-" INDICATES OVERSIZE "D" DIA.

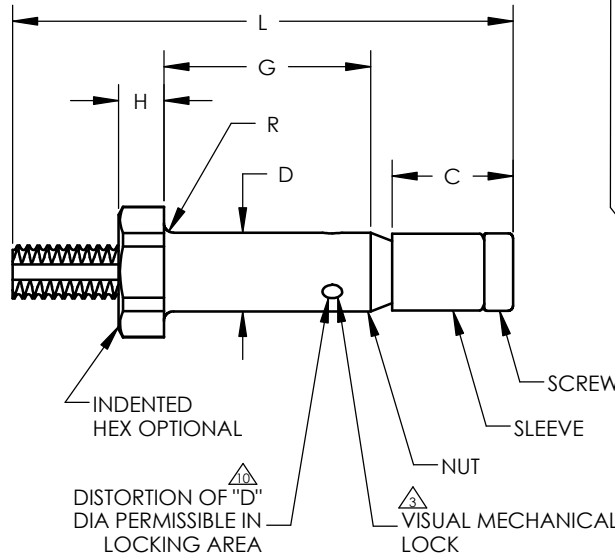

△ DISTORTION OF "D" DIA PERMISSIBLE IN LOCKING AREA

△ VISUAL MECHANICAL LOCK

BREAKOFF LIMITS  
 (MEASURED FROM SKIN SURFACE)

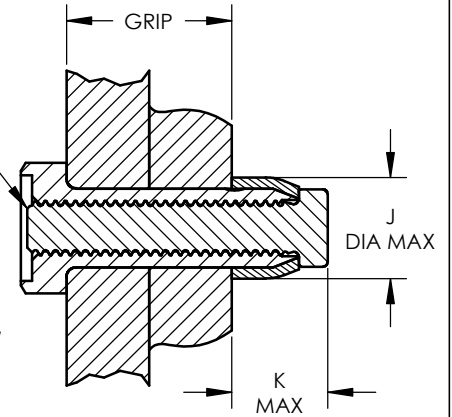

TYPICAL INSTALLATION

PART NUMBER	NOM DIA	A	C MAX	D DIA	F DRIVING FLATS	H MAX	J DIA MAX	K MAX	N MIN	R RAD	HOLE SIZE	BREAK-OFF LIMITS	PREVAILING TORQUE IN. LBS. MIN	DOUBLE SHEAR STRENGTH LBS. MIN	TENSILE STRENGTH LBS. MIN
PLT221-05-(-)	.179	.250 .244	.293	.180 .178	.086 .081	.096	.244	.272	.272	.020 .010	.183 .180	+088 +000	1.0	3150	900
PLT221-06-(-)	.214	.312 .305	.328	.215 .213	.104 .099	.113	.300	.312	.340	.025 .015	.218 .215	+103 +015	1.5	4600	1400
PLT221-08-(-)	.275	.375 .367	.379	.276 .274	.135 .130	.135	.384	.351	.409	.025 .015	.279 .276	+130 +032	2.5	7900	2100
PLT221-10-(-)	.326	.437 .429	.448	.327 .325	.152 .147	.160	.427	.426	.479	.030 .015	.330 .327	+130 +027	3.5	11350	3600
PLT221-12-(-)	.389	.500 .491	.535	.390 .388	.185 .180	.190	.516	.495	.548	.030 .015	.393 .390	+130 +027	4.0	16450	5600

SECOND DASH NUMBER	G GRIP	GRIP RANGE		L REF.				
		MIN	MAX	PLT221				
				-05-(-)	-06-(-)	-08-(-)	-10-(-)	-12-(-)
-01	.093	.031	.093	.733	.874	-	-	-
-02	.156	.094	.156	.795	.936	1.006	1.158	-
-03	.219	.157	.219	.858	.999	1.069	1.221	1.367
-04	.281	.220	.281	.920	1.061	1.131	1.283	1.429
-05	.344	.282	.344	.983	1.124	1.194	1.346	1.492
-06	.406	.345	.406	1.045	1.186	1.256	1.408	1.554
-07	.469	.407	.469	1.108	1.249	1.319	1.471	1.617
-08	.531	.470	.531	1.170	1.311	1.381	1.533	1.679
-09	.594	.532	.594	1.233	1.374	1.444	1.596	1.742
-10	.656	.595	.656	1.295	1.436	1.506	1.658	1.804
-11	.719	.657	.719	1.358	1.499	1.569	1.721	1.867
-12	.781	.720	.781	1.420	1.561	1.631	1.783	1.929
-13	.844	.782	.844	1.483	1.624	1.694	1.846	1.992
-14	.906	.845	.906	1.545	1.686	1.756	1.908	2.054
-15	.969	.907	.969	1.608	1.749	1.819	1.971	2.117
-16	1.031	.970	1.031	1.670	1.811	1.881	2.033	2.179

SECOND DASH NUMBER	G GRIP	GRIP RANGE		L REF.				
		MIN	MAX	PLT221				
				-05-(-)	-06-(-)	-08-(-)	-10-(-)	-12-(-)
-17	1.094	1.032	1.094		1.874	1.944	2.096	2.242
-18	1.156	1.095	1.156		1.936	2.006	2.158	2.304
-19	1.219	1.157	1.219		1.999	2.069	2.221	2.367
-20	1.281	1.220	1.281		2.061	2.131	2.283	2.429
-21	1.344	1.282	1.344		2.124	2.194	2.346	2.492
-22	1.406	1.345	1.406		2.186	2.256	2.408	2.554
-23	1.469	1.407	1.469		2.249	2.319	2.471	2.617
-24	1.531	1.470	1.531		2.311	2.381	2.533	2.679
-25	1.594	1.532	1.594		2.374	2.444	2.596	2.742
-26	1.656	1.595	1.656		2.436	2.506	2.658	2.804
-27	1.719	1.657	1.719		2.499	2.569	2.721	2.867
-28	1.781	1.720	1.781		2.561	2.631	2.783	2.929
-29	1.844	1.782	1.844		2.624	2.694	2.846	2.992
-30	1.906	1.845	1.906		2.686	2.756	2.908	3.054
-31	1.969	1.907	1.969		2.749	2.819	2.971	3.117
-32	2.031	1.970	2.031		2.811	2.881	3.033	3.179

▲ "G" TOLERANCE: FOR -05 AND -06 SIZES +.030/-010; FOR -08 & -10 SIZES +.040/-010; FOR -12 SIZE +.050/-010.



TITLE:  
 VISU-LOK, FASTENER, BLIND INTERNALLY THREADED, EXTERNAL SLEEVE A-286 ALLOY STEEL PROTRUDING HEX HEAD, SELF LOCKING 1/64" OVERSIZE

DRAWING NO:  
 PLT221-(-)-(-)

DRAWN BY: G.MARTINEZ DRAWN DATE: 06-22-13

APPROVED BY: CHECKED DATE:

PROPRIETARY AND CONFIDENTIAL: NOTICE: THIS DRAWING IS PART OF THE PROPRIETARY ARTICLE HEREIN DISCLOSED, OWNED BY MONOGRAM AEROSPACE FASTENERS. ANY PARTY BY ACCEPTING THIS DOCUMENT ASSUME CUSTODY THEREOF AND AGREES: A: THE INFORMATION SET FORTH HEREIN IS GIVEN IN CONFIDENCE AND THIS DOCUMENT WILL NOT BE COPIED OR REPRODUCED IN WHOLE OR IN PART, NOR ITS CONTENTS REVEALED IN ANY MANNER TO ANY PERSON EXCEPT TO MEET THE PURPOSE FOR WHICH IT WAS DELIVERED. B: WITHOUT THE WRITTEN CONSENT OF MONOGRAM AEROSPACE FASTENERS, THIS DOCUMENT AND THE INFORMATION CONTAINED HEREIN UNDER NO CIRCUMSTANCES WILL BE USED IN THE MANUFACTURE OR REPRODUCTION OF THE ARTICLE DISCLOSED, AND THE DELIVERY OF THIS DOCUMENT SHALL NOT CONSTITUTE ANY RIGHT OR LICENSE TO DO SO.

Alcoa CAGE CODE: 5M902

MONOGRAM CAGE CODE: 98524

ECN NO: 14-0678 ECN DATE: 11/04/14

REV: R SHEET 1 OF 2



PROCUREMENT SPEC: ESCBB-2 CLASS II.

MATERIAL: NUT, SCREW, & SLEEVE: CORROSION RESISTANT STEEL, TYPE A-286 PER AMS5731, AMS5732 OR AMS5737.

HEAT TREAT: NUT, SCREW, & SLEEVE: SOLUTION HEAT TREATED AND AGED TO A CORE HARDNESS OF HRC 30 TO 45. ALL CORE HARDNESS READINGS ARE TAKEN ON MOUNTED SPECIMEN, USING A BRALE PENETRATOR AND A 30 Kg LOAD (ROCKWELL 30N).

FINISH: NUT, SCREW, & SLEEVE: PASSIVATE PER AMS2700.

LUBRICANT: LUBRICANTS LISTED BELOW MAY BE APPLIED TO ANY OR ALL COMPONENTS IF REQUIRED FOR PERFORMANCE.  
 DRY FILM LUBE PER AS5272 TYPE I OR MIL-PRF-81329, WWM CARBO-WAX, PARAFFIN WAX AND/OR CETYL ALCOHOL PER AS87132.

PART CODE & EXAMPLE: PLT221 - 05 - 05

GRIP LENGTHS IN 1/16THS  
 NOMINAL BODY DIAMETER AS TABULATED  
 BASIC PART NUMBER, SELF LOCKING BLIND FASTENER

GENERAL NOTES:

1. OUTSIDE DIAMETER OF HEAD OF SCREW AND OUTSIDE DIAMETER OF SLEEVE SHALL NOT EXCEED MAXIMUM "D" DIAMETER.
2. REMOVE ALL LOOSE OR HANGING BURRS.
3. LOCKING FEATURE CONSISTS OF THREE (3) INDENTATIONS LOCATED 120° APART ON THE PERIPHERY OF THE NUT COMPONENT AND APPROXIMATELY .040 ABOVE THE INTERSECTION OF THE NUT NOSE ANGLE AND O.D. (MEAN GRIP OF FASTENER).
4. THE PREVAILING TORQUE SHALL CONFORM TO THE VALUES AS TABULATED, WHEN TESTED IN ACCORDANCE WITH SPECIFICATION ESCBB-2. HOWEVER, PREVAILING TORQUES FOR THE PLT221-05-01 AND PLT221-06-01 SHALL BE RECORDED THRU A ROTATION OF ONLY 360° OF THE NUT.
5. MANUFACTURER'S IDENTIFICATION: (REFER TO NOTE 7 FOR INTERIM IDENTIFICATION)  
 LETTER "N" DESIGNATES MONOGRAM AEROSPACE FASTENERS.  
 LETTERS "VS" DESIGNATE VOI-SHAN.
6. HEAD MARKINGS ON NUT DEPRESSED .010 MAX.
7. THE PRODUCT DESCRIBED BY THIS DRAWING IS "EQUIVALENT TO" AND "INTERCHANGEABLE WITH" THE MANUFACTURER'S PRODUCT LISTED BELOW EXCEPT FOR COLOR IDENTIFICATION, HEAD MARKING, AND SELF-LOCKING FEATURE. EXISTING STOCK MAY BE REWORKED TO COLOR AND HEAD MARKING MAY BE AS SHOW BELOW:  
 MONOGRAM.... PL0164A-PL0375A SERIES MARKING: "-" AND/OR "N" OVERSTAMPED "L" OR "SL"; NUT MAYBE COLORED RED.  
 VOI-SHAN.... VA 407 SERIES MARKING: "VS", "O", "V" AND "SL"; NUT MAYBE COLORED GOLD.
8. STANDARD FINISHES AND LUBRICANTS ARE SHOWN ABOVE. REFER TO SPECIFICATION ESCBB-4 FOR SPECIAL FINISHES AND/OR LUBRICANTS, IF REQUIRED.
9. HALF-GRIP SIZES MAY BE ORDERED BY ADDING (.5) TO THE GRIP DASH NUMBERS.  
 EXAMPLE: PLT221-06-4.5 INDICATES A NOMINAL GRIP LENGTH OF 4.5 SIXTEENTHS = .281.  
 THE GRIP RANGE FOR THESE HALF-GRIP SIZES WILL BE NOMINAL GRIP +.031/- .030.  
 THE BASIC "G" DIMENSION WILL BE NOMINAL GRIP +.031 AND THE OVERALL SCREW LENGTH "L" DIMENSION MAY VARY AT MANUFACTURER'S OPTION.
10. DISTORTION OF "D" DIAMETER SHALL NOT PREVENT INSERTION OF THE FASTENER INTO A RING GAUGE OF LENGTH EQUAL TO ONE DIAMETER AND DIAMETER EQUAL TO MAXIMUM "D" + .001". FORCE FOR INSERTION SHALL NOT EXCEED FIVE (5) POUNDS.
11. STANDARD GRIP LENGTHS ARE AS TABULATED, SHORTER OR LONGER GRIPS THAN THOSE LISTED MAY BE AVAILABLE AS SPECIALS. ON GRIP LENGTHS SHORTER THAN THOSE LISTED, THE BREAKOFF LIMITS AND PREVAILING TORQUES AS TABULATED DO NOT APPLY.
12. DIMENSIONS ARE EXCLUSIVE OF LUBRICATION.



TITLE: VISU-LOK, FASTENER, BLIND INTERNALLY THREADED, EXTERNAL SLEEVE A-286 ALLOY STEEL PROTRUDING HEX HEAD, SELF LOCKING 1/64" OVERSIZE

DRAWING NO: PLT221-( )-( )

DRAWN BY: G.MARTINEZ DRAWN DATE: 06-22-13

APPROVED BY: CHECKED DATE:

PROPRIETARY AND CONFIDENTIAL: NOTICE: THIS DRAWING IS PART OF THE PROPRIETARY ARTICLE HEREIN DISCLOSED, OWNED BY MONOGRAM AEROSPACE FASTENERS. ANY PARTY BY ACCEPTING THIS DOCUMENT ASSUME CUSTODY THEREOF AND AGREES: A: THE INFORMATION SET FORTH HEREIN IS GIVEN IN CONFIDENCE AND THIS DOCUMENT WILL NOT BE COPIED OR REPRODUCED IN WHOLE OR IN PART, NOR ITS CONTENTS REVEALED IN ANY MANNER TO ANY PERSON EXCEPT TO MEET THE PURPOSE FOR WHICH IT WAS DELIVERED. B: WITHOUT THE WRITTEN CONSENT OF MONOGRAM AEROSPACE FASTENERS, THIS DOCUMENT AND THE INFORMATION CONTAINED HEREIN UNDER NO CIRCUMSTANCES WILL BE USED IN THE MANUFACTURE OR REPRODUCTION OF THE ARTICLE DISCLOSED, AND THE DELIVERY OF THIS DOCUMENT SHALL NOT CONSTITUTE ANY RIGHT OR LICENSE TO DO SO.

Alcoa CAGE CODE: 5M902

MONOGRAM CAGE CODE: 98524

ECN NO: 14-0678 ECN DATE: 11/04/14

REV: R SHEET 2 OF 2