

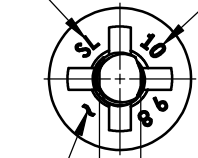

FASTENER IDENTIFICATION MARK "1098" (ARRANGEMENT OPTIONAL)

"SL" INDICATES MECHANICAL SELF LOCK



F DRIVING FLATS

MANUFACTURER'S IDENTIFICATION

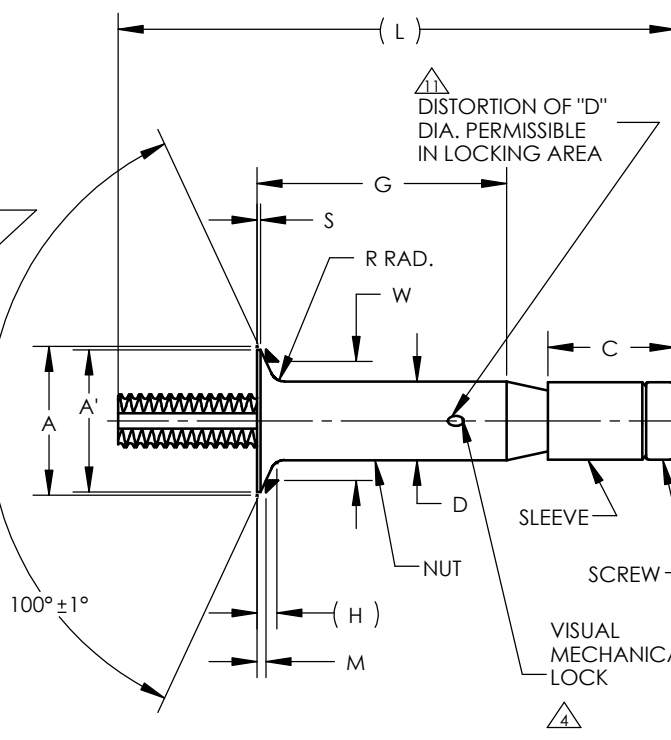

2X ØE

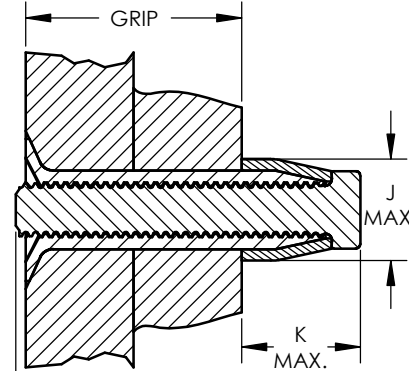

BREAK-OFF LIMITS (MEASURED FROM HEAD OF NUT)

TYPICAL INSTALLATION

PART NUMBER	NOM DIA.	A THEO DIA.	A' DIA. MIN.	C MAX.	D DIA.	E MAX.	F DRIVING FLATS	H REF.	J DIA. MAX.	K MAX.	M GAGE PROT.	R RAD.	S MAX.	W GAGE DIA.	RECOMMENDED HOLE SIZE	BREAK-OFF LIMITS	PREVAILING TORQUE IN. LBS. MIN.	DOUBLE SHEAR STRENGTH LBS. MIN.	TENSILE STRENGTH LBS. MIN.
PLT1098-05-(-)	.1795	.332 .325	.296	.293	.1800 .1790	.177	.086 .081	.063	.244	.272	.0276 .0238	.030 .010	.012	.2671 .2667	.183 .180	+020 -.068	1.0	3355	900
PLT1098-06-(-)	.2130	.385 .378	.342	.328	.2150 .2140	.212	.104 .099	.070	.300	.312	.0299 .0259	.030 .015	.015	.3147 .3143	.218 .215	+015 -.073	1.5	5240	1400
PLT1098-08-(-)	.2755	.507 .499	.463	.379	.2760 .2750	.273	.135 .130	.095	.384	.351	.0353 .0307	.030 .015	.015	.4245 .4241	.279 .276	+010 -.078	2.5	9000	2100
PLT1098-10-(-)	.3265	.635 .626	.577	.448	.3270 .3260	.324	.152 .147	.128	.427	.426	.0409 .0357	.040 .020	.020	.5389 .5385	.330 .327	+010 -.083	3.5	12000	3600
PLT1098-12-(-)	.3895	.762 .752	.696	.535	.3900 .3890	.387	.185 .180	.154	.516	.495	.0466 .0407	.040 .020	.023	.6532 .6528	.393 .390	+010 -.093	4.0	19500	5600

SECOND DASH NUMBER	G GRIP	GRIP RANGE		L REF. PLT1098				
		8 MIN	9 MAX	-05-(-)	-06-(-)	-08-(-)	-10-(-)	-12-(-)
-	-	-	-	-	-	-	-	-
-02	.156	.094	.156	.733	.853	-	-	-
-03	.219	.157	.219	.795	.916	.944	-	-
-04	.281	.220	.281	.858	.978	1.006	1.158	1.242
-05	.344	.282	.344	.920	1.041	1.069	1.221	1.304
-06	.406	.345	.406	.983	1.103	1.131	1.283	1.367
-07	.469	.407	.469	1.045	1.166	1.194	1.346	1.429
-08	.531	.470	.531	1.108	1.228	1.256	1.408	1.492
-09	.594	.532	.594	1.170	1.291	1.319	1.471	1.554
-10	.656	.595	.656	1.233	1.353	1.381	1.533	1.617
-11	.719	.657	.719	1.295	1.416	1.444	1.596	1.679
-12	.781	.720	.781	1.358	1.478	1.506	1.658	1.742
-13	.844	.782	.844	1.420	1.541	1.569	1.721	1.804
-14	.906	.845	.906	1.483	1.603	1.631	1.783	1.867
-15	.969	.907	.969	1.545	1.666	1.694	1.846	1.929
-16	1.031	.970	1.031	1.608	1.728	1.756	1.908	1.992

SECOND DASH NUMBER	G GRIP	GRIP RANGE		L REF. PLT1098				
		8 MIN	9 MAX	-05-(-)	-06-(-)	-08-(-)	-10-(-)	-12-(-)
-17	1.094	1.032	1.094	1.791	1.819	1.971	2.054	
-18	1.156	1.095	1.156	1.853	1.881	2.033	2.117	
-19	1.219	1.157	1.219	1.916	1.944	2.096	2.179	
-20	1.281	1.220	1.281	1.978	2.006	2.158	2.242	
-21	1.344	1.282	1.344	2.041	2.069	2.221	2.304	
-22	1.406	1.345	1.406	2.103	2.131	2.283	2.367	
-23	1.469	1.407	1.469	2.166	2.194	2.346	2.429	
-24	1.531	1.470	1.531	2.228	2.256	2.408	2.492	
-25	1.594	1.532	1.594	2.291	2.319	2.471	2.554	
-26	1.656	1.595	1.656	2.353	2.381	2.533	2.617	
-27	1.719	1.657	1.719	2.416	2.444	2.596	2.679	
-28	1.781	1.720	1.781	2.478	2.506	2.658	2.742	
-29	1.844	1.782	1.844	2.541	2.569	2.721	2.804	
-30	1.906	1.845	1.906	2.603	2.631	2.783	2.867	
-31	1.969	1.907	1.969	2.666	2.694	2.846	2.929	
-32	2.031	1.970	2.031	2.728	2.756	2.908	2.992	

▲ "G" TOLERANCE: FOR -05 AND -06 SIZES +.030/-010; FOR -08 & -10 SIZES +.040/-010; FOR -12 SIZES +.050/-010.



3423 SOUTH GARFIELD AVENUE  
COMMERCE, CALIFORNIA 90040  
(323) 722-4760 FAX (323) 727-1029

TITLE:

VISU-LOK, FASTENER, BLIND INTERNALLY THREADED, EXTERNAL SLEEVE ALLOY STEEL  
100° FLUSH HEAD, SELF LOCKING GROUND SHANK, 1/64" OVERSIZE

DRAWING NO:

PLT1098-(-)(-)

DRAWN BY:

B. GEE

DRAWN DATE:

12/12/13

APPROVED BY:

CHECKED DATE:

PROPRIETARY AND CONFIDENTIAL: NOTICE: THIS DRAWING IS PART OF THE PROPRIETARY ARTICLE HEREIN DISCLOSED, OWNED BY MONOGRAM AEROSPACE FASTENERS. ANY PARTY BY ACCEPTING THIS DOCUMENT ASSUME CUSTODY THEREOF AND AGREES:  
A: THE INFORMATION SET FORTH HEREIN IS GIVEN IN CONFIDENCE AND THIS DOCUMENT WILL NOT BE COPIED OR REPRODUCED IN WHOLE OR IN PART, NOR ITS CONTENTS REVEALED IN ANY MANNER TO ANY PERSON EXCEPT TO MEET THE PURPOSE FOR WHICH IT WAS DELIVERED.  
B: WITHOUT THE WRITTEN CONSENT OF MONOGRAM AEROSPACE FASTENERS, THIS DOCUMENT AND THE INFORMATION CONTAINED HEREIN UNDER NO CIRCUMSTANCES WILL BE USED IN THE MANUFACTURE OR REPRODUCTION OF THE ARTICLE DISCLOSED, AND THE DELIVERY OF THIS DOCUMENT SHALL NOT CONSTITUTE ANY RIGHT OR LICENSE TO DO SO.

Alcoa  
CAGE CODE:

5M902

MONOGRAM  
CAGE CODE:

98524

DCN NO:  
17-0056

DCN DATE:  
02/23/17

REV:

F

SHEET 1 OF 2



PROCUREMENT SPEC: ESCBB-2, CLASS 1, EXCEPT AS SPECIFIED HEREIN.

MATERIAL: NUT & SCREW: ALLOY STEEL: 4130 PER AMS-S-6758, 4140 PER AMS6382 OR AMS6349 OR 8740 PER AMS6322.

SLEEVE: CORROSION RESISTANT STEEL: 303 OR 304 PER AMS-QQ-S-763, AMS5639 OR AMS5641.

HEAT TREAT: NUT & SCREW: HEAT TREAT PER AMS2759 TO HRC 39-46.

SLEEVE: AS REQUIRED FOR PERFORMANCE.

7 FINISH: NUT & SCREW: CADMIUM PLATE PER AMS-QQ-P-416, TYPE II, CLASS 2. CADMIUM PLATE PER NAS672 IS PERMISSIBLE PROVIDED IT IS FOLLOWED BY A DICHROMATE POST TREATMENT PER AMS-QQ-P-416.

SLEEVE: PASSIVATE PER AMS2700. CADMIUM PLATE PER AMS-QQ-P-416, TYPE 1, CLASS 3.

7 LUBRICANT: LUBRICANTS LISTED BELOW MAY BE APPLIED TO ANY OR ALL COMPONENTS IF REQUIRED FOR FASTENER PERFORMANCE:

NUT: WWM CARBO-WAX, PARAFFIN WAX, AND/OR CETYL ALCOHOL PER AS87132.

SCREW & SLEEVE: DRY FILM LUBE PER AS5272 OR MIL-PRF-81329, WWM CARBO-WAX, PARAFFIN WAX, AND/OR CETYL ALCOHOL PER AS87132.

PART CODE & EXAMPLE:

PLT1098 - 08 - 08



GENERAL NOTES:

- 1. OUTSIDE DIAMETER OF HEAD OF SCREW AND OUTSIDE DIAMETER OF SLEEVE SHALL NOT BE GREATER THAN MAXIMUM "D" DIAMETER.
2. CONCENTRICITY OF NUT HEAD CONICAL SURFACE TO "D" DIAMETER SHALL BE WITHIN .005" T.I.R., (EXCEPT OVER INDENTS).
3. REMOVE ALL LOOSE OR HANGING BURRS.

4. LOCKING FEATURE CONSISTS OF THREE (3) INDENTATIONS LOCATED 120° APART ON THE PERIPHERY OF THE NUT COMPONENT AND APPROXIMATELY .040" ABOVE THE INTERSECTION OF THE NUT NOSE ANGLE AND O.D. (MEAN GRIP OF FASTENER).

5. MANUFACTURER'S IDENTIFICATION: LETTER "N" DESIGNATES MONOGRAM AEROSPACE FASTENERS. LETTERS "VS" DESIGNATE VOI-SHAN.

6. HEAD MARKINGS ON NUT DEPRESSED .010" MAX. LOCATION OPTIONAL.

7. STANDARD FINISHES AND LUBES ARE SHOWN ABOVE. REFER TO ESCBB-4 FOR SPECIAL FINISHES AND/OR LUBES, IF REQUIRED.

8. HALF-GRIP SIZES MAY BE ORDERED BY ADDING (.5) TO THE GRIP DASH NUMBERS.

EXAMPLE: PLT1098-06-4.5 INDICATES A NOMINAL GRIP LENGTH OF 4.5 SIXTEENTHS = 0.281". THE GRIP RANGE FOR THESE HALF-GRIP SIZES WILL BE NOMINAL GRIP +.031"/-.030". EXCEPT: THE GRIP RANGE FOR -1.5 GRIP SHALL BE MAX GRIP = 0.125", MIN GRIP = 0.078". THE BASIC "G" DIMENSION WILL BE NOMINAL GRIP +.031" AND THE OVERALL SCREW LENGTH "L" DIMENSION MAY VARY AT MANUFACTURER'S OPTION.

9. STANDARD GRIP LENGTHS ARE AS TABULATED. SHORTER OR LONGER GRIPS THAN THOSE LISTED MAY BE AVAILABLE AS SPECIALS. ON GRIP LENGTHS SHORTER THAN THOSE LISTED, THE BREAKOFF LIMITS AND PREVAILING TORQUES AS TABULATED DO NOT APPLY.

10. PLT1098 IS A 1/64" OVERSIZE VERSION OF PLT114.

11. DISTORTION OF "D" DIAMETER SHALL NOT PREVENT INSERTION OF THE FASTENER INTO A RING GAUGE OF LENGTH EQUAL TO ONE DIAMETER AND DIAMETER EQUAL TO MAXIMUM "D" + .001". FORCE FOR INSERTION SHALL NOT EXCEED FIVE (5) POUNDS.

12. DIMENSIONS "A", "A'", AND "H" ARE FOR ENGINEERING REFERENCE PURPOSES ONLY AND ARE NOT TO BE USED FOR INSPECTION PURPOSES. THESE DIMENSIONS ARE THEORETICAL VALUES DERIVED FROM "D", "S", "V", "W" AND HEAD ANGLE DIMENSIONS.

13. DIMENSIONS ARE EXCLUSIVE OF LUBRICATION.

14. GROUND SHANK VISU-LOKS SHOULD NOT BE USED, EXCEPT WITH CONSIDERABLE CAUTION, IN APPLICATIONS WHICH EXCEED .0005 INTERFERENCE FIT. GROUND SHANK VISU-LOKS WILL PERFORM SATISFACTORILY WHEN INSTALLED IN THE TABULATED HOLE SIZES.



3423 SOUTH GARFIELD AVENUE
COMMERCE, CALIFORNIA 90040
(323) 722-4760 FAX (323) 727-1029

TITLE:

VISU-LOK, FASTENER, BLIND INTERNALLY THREADED, EXTERNAL SLEEVE ALLOY STEEL 100° FLUSH HEAD, SELF LOCKING GROUND SHANK, 1/64" OVERSIZE

DRAWING NO:

PLT1098-( )-( )

DRAWN BY:

B. GEE

DRAWN DATE:

12/12/13

APPROVED BY:

CHECKED DATE:

PROPRIETARY AND CONFIDENTIAL: NOTICE: THIS DRAWING IS PART OF THE PROPRIETARY ARTICLE HEREIN DISCLOSED, OWNED BY MONOGRAM AEROSPACE FASTENERS. ANY PARTY BY ACCEPTING THIS DOCUMENT ASSUME CUSTODY THEREOF AND AGREES: A: THE INFORMATION SET FORTH HEREIN IS GIVEN IN CONFIDENCE AND THIS DOCUMENT WILL NOT BE COPIED OR REPRODUCED IN WHOLE OR IN PART, NOR ITS CONTENTS REVEALED IN ANY MANNER TO ANY PERSON EXCEPT TO MEET THE PURPOSE FOR WHICH IT WAS DELIVERED. B: WITHOUT THE WRITTEN CONSENT OF MONOGRAM AEROSPACE FASTENERS, THIS DOCUMENT AND THE INFORMATION CONTAINED HEREIN UNDER NO CIRCUMSTANCES WILL BE USED IN THE MANUFACTURE OR REPRODUCTION OF THE ARTICLE DISCLOSED, AND THE DELIVERY OF THIS DOCUMENT SHALL NOT CONSTITUTE ANY RIGHT OR LICENSE TO DO SO.

Alcoa CAGE CODE: 5M902

MONOGRAM CAGE CODE: 98524

DCN NO: 17-0056 DCN DATE: 02/23/17

REV: F SHEET 2 OF 2