

# ALLFAST

FASTENING SYSTEMS, INC.

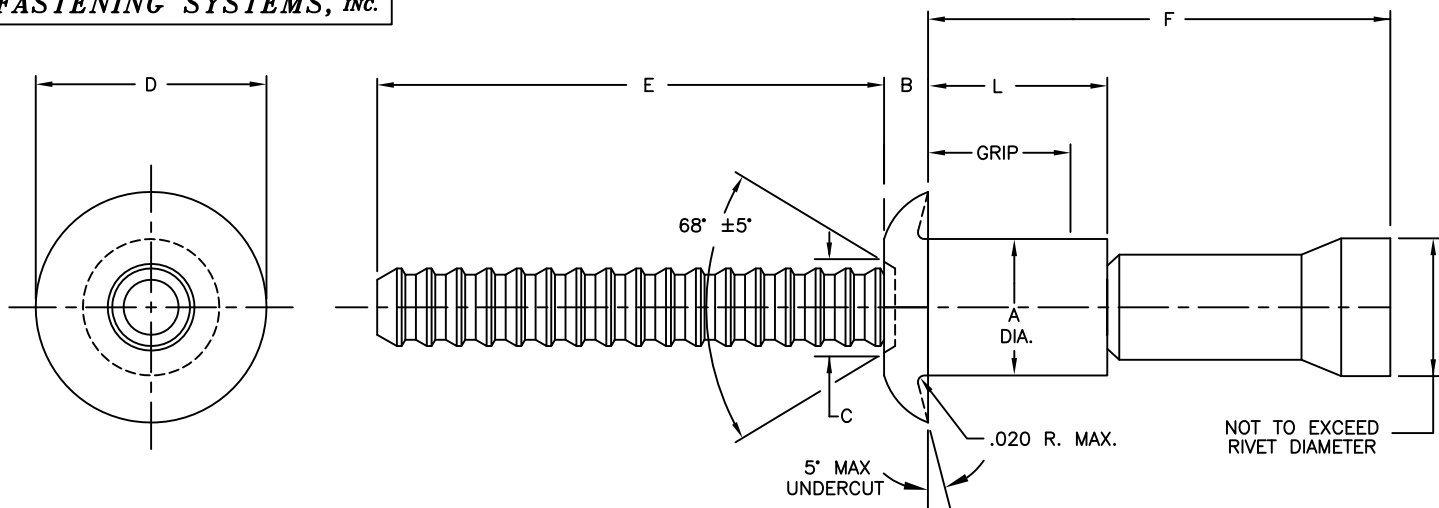

NOM. DIA.	A +.003 -.001	B +.010 -.000	C MAX.	D DIA.	E MIN.	RECOMMENDED PROCEDURE	
						DRILL SIZE	HOLE LIMITS
1/8	.125	.054	.110	.250 ±.012	3/4"	#30 (.1285)	.132/.128
5/32	.156	.067	.138	.312 ±.016	3/4"	#20 (.1610)	.164/.160
3/16	.187	.080	.161	.375 ±.019	3/4"	#10 (.1935)	.196/.192
1/4	.250	.107	.215	.500 ±.025	1"	F (.257)	.256/.261

GRIP RANGE		DASH NO.	1/8" DIA. (-4)		5/32" DIA. (-5)		3/16" DIA. (-6)		1/4" DIA. (-8)	
MIN.	MAX.		L MAX.	F MAX.	L MAX.	F MAX.	L MAX.	F MAX.	L MAX.	F MAX.
.063	.125	-1	.170	.500	.192	.558	.215	.638		
.126	.187	-2	.232	.600	.254	.620	.217	.700		
.188	.250	-3	.295	.750	.317	.808	.340	.888	.385	.970
.251	.312	-4	.357	.850	.379	.870	.402	.950	.447	1.090
.313	.375	-5	.420	1.010	.441	1.058	.465	1.138	.510	1.220
.376	.437	-6	.482	1.100	.503	1.120	.527	1.200	.572	1.340
.438	.500	-7	.545	1.197	.567	1.339	.590	1.419	.635	1.470
.501	.562	-8	.607	1.322	.629	1.401	.652	1.481	.697	1.590
.563	.625	-9	.670	1.509	.692	1.567	.715	1.637	.760	1.720
.626	.687	-10			.754	1.630	.777	1.699	.822	1.840
.688	.750	-11			.817	1.817	.840	1.887	.885	1.970
.751	.812	-12			.879	1.880	.902	1.949	.947	2.090
.813	.875	-13			.942	2.067	.965	2.074	1.010	2.220
.875	.937	-14			1.004	2.130	1.027	2.199	1.072	2.340
.937	1.000	-15							1.134	2.405
1.000	1.062	-16							1.196	2.530

SERIES	MATERIAL		FINISH	
	SLEEVE	STEM	SLEEVE	STEM
AF6050 MS20600B	5056 ALUMINUM ALLOY	2017-T4 ALUMINUM ALLOY	MIL-A-8625 OR MIL-DTL-5541 (ORANGE)	MIL-A-8625 OR MIL-DTL-5541
AF6000 MS20600AD	2117-T4 ALUMINUM ALLOY	2017-T4 ALUMINUM ALLOY	MIL-A-8625 OR MIL-DTL-5541	MIL-A-8625 OR MIL-DTL-5541
AF6090 MS20600M	MONEL	MONEL	BARE	NONE
AF6090C MS20600MP	MONEL	MONEL	CADMIUM PLATED TYPE II	NONE
AF6090ML MS20600ML	MONEL	MONEL	SILVER PLATED	NONE

△ MINIMUM GRIP: -4-1 .025, -5-1 .031, -6-1 .037

**UNCONTROLLED COPY  
WILL NOT BE KEPT UP TO DATE**

	BY:	DATE	REV.	BY	DATE	C.R.NO.	
PREPARED:	LAUREN VARGAS	06/29/93	C	L.D.	04/16/07	6066	RIVET BLIND SELF-PLUGGING UNIVERSAL HEAD  AF6000
CHECKED:	<b>APPROVAL</b>		D	P.M.	12/09/10	7179	
APPROVED:	<b>ON FILE</b>		E	P.M.	10/18/12	7932	